

MODEL CD-750

PORTABLE AM/FM STEREO CD

MP3 ENCODER/PLAYER

USER MANUAL



Please read this User Manual carefully before using the unit and retain it for future reference

DEAR JENSEN® CUSTOMER

Selecting fine audio equipment such as the unit you've just purchased is only the start of your musical enjoyment. Now it's time to consider how you can maximize the fun and excitement your equipment offers. This manufacturer and the Electronic Industries Association's Consumer Electronics Group want you to get the most out of your equipment by playing it at a safe level. One that lets the sound come through loud and clear without annoying blaring or distortion and, most importantly, without affecting your sensitive hearing. Sound can be deceiving. Over time your hearing "comfort level" adapts to higher volumes of sound. So what sounds "normal" can actually be loud and harmful to your hearing. Guard against this by setting your equipment at a safe level BEFORE your hearing adapts.

To establish a safe level:

- Start your volume control at a low setting.
- Slowly increase the sound until you can hear it comfortably and clearly, and without distortion.

Once you have established a comfortable sound level:

- Set the dial and leave it there.

Taking a minute to do this now will help to prevent hearing damage or loss in the future. After all, we want you listening for a lifetime.

We Want You Listening For a Lifetime

Used wisely, your new sound equipment will provide a lifetime of fun and enjoyment. Since hearing damage from loud noise is often undetectable until it is too late, this manufacturer and the Electronic Industries Association's Consumer Electronics Group recommend you avoid prolonged exposure to excessive noise.

Customer's Record:

The serial number of this product is found on its bottom cover. You should note the serial number of this unit in the space provided as a permanent record of your purchase to aid in identification in the event of theft or loss.

Model Number: CD-750

Serial Number: _____

IMPORTANT SAFETY INSTRUCTIONS

When used in the directed manner, this unit has been designed and manufactured to ensure your personal safety. However, improper use can result in potential electrical shock or fire hazards. Please read all safety and operating instructions carefully before installation and use, and keep these instructions handy for future reference. Take special note of all warnings listed in these instructions and on the unit.

1. Read these instructions – All the safety and operating instructions should be read before the appliance is operated.
2. Keep these instructions – The safety and operating instructions should be kept for future reference.
3. Heed all warnings – All warnings on the appliance and in the operating instructions should be adhered to.
4. Follow all instructions – All operation and use instructions should be followed.
5. Do not use this apparatus near water – The appliance should not be used near water; for example, near a bath tub, washbowl, kitchen sink, laundry tub, in a wet basement, or near a swimming pool.
6. Clean only with dry cloth – The appliance should be cleaned only as recommended by the manufacturer.
7. Do not block any ventilation openings. Install in accordance with the manufacturer's instructions. The appliance should be situated so that its location or position does not interfere with its proper ventilation. For example, the appliance should not be situated on a bed, sofa, rug, or similar surface that may block the ventilation openings; or placed in a built-in installation, such as a bookcase or cabinet that may impede the flow of air through the ventilation openings.
8. Do not install near any heat sources such as radiators, heat registers, stoves, or other apparatus (including amplifiers) that produce heat.
9. Protect the power cord from being walked on or pinched particularly at plugs, convenience receptacles, and the point where they exit from the apparatus.
10. The system has an AC plug and will only fit into matching AC outlets. This is a safety feature to reduce the possibility of electric shock. If the plug will not fit in your AC outlets, you should have the outlet changed by qualified licensed electrician. Do not use an adaptor to make the plug fit into your outlet. This defeats the safety feature and could expose you to electric shock.
11. Only use attachments / accessories specified by the manufacturer.
12. Unplug this apparatus during lightning storms or when unused for long periods of time.
13. Refer all servicing to qualified service personnel. Servicing is required when the apparatus has been damaged in any way, such as power-

supply cord or plug is damaged, liquid has been spilled or objects have fallen into the apparatus, the apparatus has been exposed to rain or moisture, does not operate normally, or has been dropped.

14. This appliance shall not be exposed to dripping or splashing water and that no object filled with liquids such as vases shall be placed on the apparatus.
15. Power Sources – The appliance should be connected to a power supply only of the type described in the operating instructions or as marked on the appliance. Do not overload wall outlet.
16. Danger of explosion if battery is incorrectly replaced. Replace only with the same or equivalent type.
17. There is a high energy rechargeable battery inside the speaker box, do not throw it into fire to avoid danger of explosion.
18. Do not charge the internal rechargeable battery longer than specified to prevent danger of fire. Overcharging rechargeable batteries may shorten their life span.
19. Do not attempt to dismantle, open or repair this product yourself. If a fault occurs, seek advice from your local qualified service technician or contact the distributor via the telephone number at the back of this instruction manual.
20. The CAUTION mark and nameplate are located on the bottom of product.

COMPLIANCE WITH FCC REGULATIONS

This device complies with Part 15 of the FCC Rules. Operation is subject to the following two conditions:

- (1) this device may not cause harmful interference, and
- (2) this device must accept any interference received, including interference that may cause undesired operation.

NOTE: This equipment has been tested and found to comply with the limits for a Class B digital device, pursuant to Part 15 of the FCC Rules. These limits are designed to provide reasonable protection against harmful interference in a residential installation. This equipment generates, uses and can radiate radio frequency energy and, if not installed and used in accordance with the instructions, may cause harmful interference to radio communications. However, there is no guarantee that interference will not occur in a particular installation. If this equipment does cause harmful interference to radio or television reception, which can be determined by turning the equipment off and on, the user is encouraged to try to correct the interference by one or more of the following measures:

- Reorient or relocate the receiving antenna.
- Increase the separation between the equipment and receiver.
- Connect the equipment into an outlet on a circuit different from that to which the receiver is connected.
- Consult the dealer or an experienced radio/TV technician for help.

WARNING:

Changes or modifications not expressly approved by the party responsible for compliance could void the user's authority to operate the equipment.

CAUTION

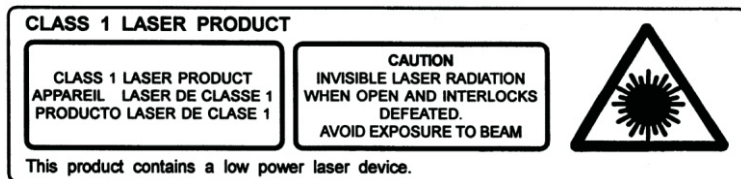

Follow the advice below for safe operations.

ON PROTECTION AGAINST LASER ENERGY EXPOSURE

- As the laser beam used in this compact disc player is harmful to the eyes, do not attempt to disassemble the casing.
- Stop operation immediately if any liquid or solid object should fall into the cabinet.
- Do not touch the lens or poke at it. If you do, you may damage the lens and the player may not operate properly.
- Do not put anything in the safety slot. If you do, the laser diode will be ON when the CD door is still open.
- If the unit is not to be used for a long period of time, make sure that all power sources are disconnected from the unit.
- This unit employs a laser. The use of controls or adjustment or performance of procedures other than those specified here may result in exposure to hazardous radiation.

Should any trouble occur, remove the power source and refer servicing to qualified personnel.

PROTECT YOUR FURNITURE !

This model is equipped with non-skid rubber 'feet' to prevent the product from moving when you operate the controls. These 'feet' are made from non-migrating rubber material specially formulated to avoid leaving any marks or stains on your furniture. However certain types of oil based furniture polishes, wood preservatives, or cleaning sprays may cause the rubber 'feet' to soften, and leave marks or a rubber residue on the furniture. To prevent any damage to your furniture we strongly recommend that you purchase small self-adhesive felt pads, available at hardware stores and home improvement centers everywhere, and apply these pads to the bottom of the rubber 'feet' before you place the product on fine wooden furniture.

IMPORTANT NOTES

Avoid installing the unit in locations described below:

- Places exposed to direct sunlight or close to heat radiating appliances such as electric heaters.
- Places subject to constant vibration.
- Dusty, humid or moist places.

FUNCTIONS OF CONTROLS

MAIN UNIT

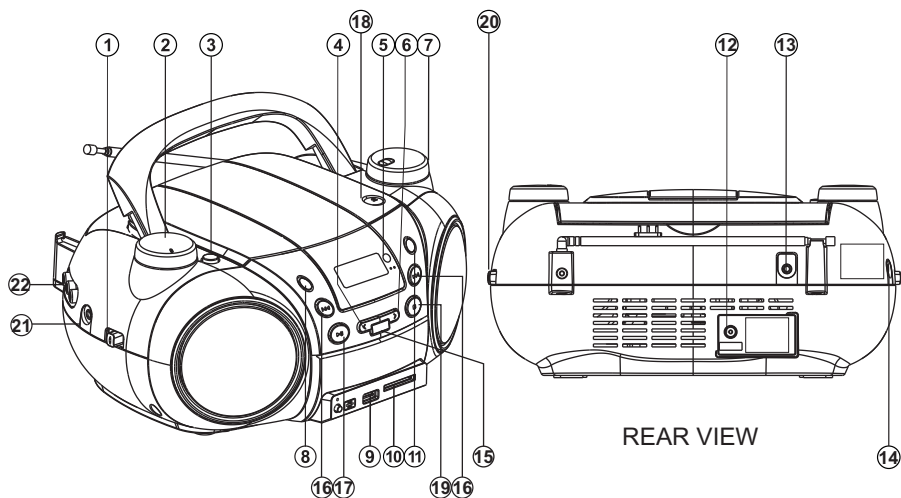

1. **Function Selector**
2. **Volume Control**
3. **POWER Button**
4. **FOLDER -**
5. **Remote Sensor**
6. **FOLDER +**
7. **Tuning Control**
8. **REPEAT Button**
9. **USB Port**
10. **SD/MMC Slot**
11. **DISC/USB/SD Function Button**
12. **DC Jack**
13. **HEADPHONE Jack**
14. **LINE IN (AUX) Jack**
15. **ENCODE**
16. **SKIP NEXT/ SKIP BACK ►► / ◄◄ buttons**
17. **PLAY/PAUSE ►||**
18. **CD Door Open Button**
19. **STOP button ■**
20. **BAND SELECTOR**
21. **HEADPHONE JACK**
22. **LINE OUT JACK**

LCD DISPLAY UNIT

1. **CD** : CD disc indicator
PGM : Program play indicator
RAN : Random play mode indicator
REP1 : Repeat one track/ chapter indicator
REP ALL : Repeat the entire disc
USB : USB function indicator
SD : (SD or MMC) card
2. **▶** : Disc play indicator
|| : Pause indicator
3. Message or number indicators
(Title, Chapter, playing time or other information)

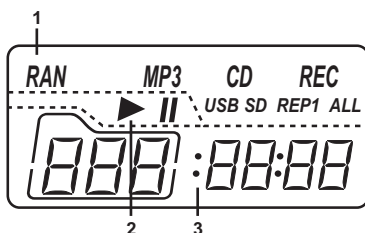

REMOTE CONTROL UNIT

1. NUMERIC KEYS
2. REPEAT BUTTON (REP)
3. CD RIPPING AND FILE COPY (ENCODE)
4. PLAY/PAUSE BUTTON (▶||)
5. STOP BUTTON (■)
6. PREVIOUS BUTTON (◀◀)
7. NEXT BUTTON (▶▶)
8. DISC/USB/SD BUTTON
9. RANDOM BUTTON
10. VOLUME + BUTTON
11. VOLUME - BUTTON

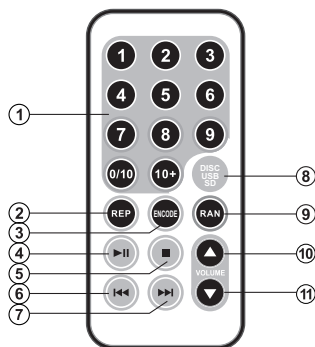

NOTE:

- The remote control does not adjust the radio frequency.
- The volume up/down on the remote control does not adjust the master volume of the unit.

ACTIVATING THE REMOTE CONTROL

Remove the plastic insulator tag sticking out of the Battery Compartment of the Remote Control by pulling on it. Once the tag is removed, the Remote Control will be ready for use.

BATTERY CARE

- i. If the unit is not to be used for an extended period of time, remove the battery. Old or leaking battery can cause damage to the Remote Control.

- ii. Do not dispose of batteries in fire, batteries may explode or leak.

BATTERY REPLACEMENT

When the battery becomes weak, the operating distance of the Remote Control is greatly reduced and you will need to replace the Lithium battery.

1. Remove the battery compartment from bottom of the Remote Control.
2. Install 1 "CR2025" Lithium battery with the positive side facing up.
3. Replace the battery compartment.

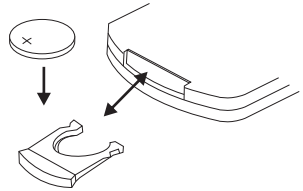

IMPORTANT: Be sure that the battery is installed correctly. Wrong polarity may damage the Remote Control and void the warranty.

The Remote Control may not operate correctly when:

- The unit is exposed to intense light, such as direct sunlight
- Objects block the remote control signal to the unit

To use the buttons on the Remote Control

Buttons on the remote control and the main unit with identical indications have the same functions.

Operating the Remote Control

Normal operating distance for the remote is 15-20 feet from the unit and at an angle of no more than 60°.

REMOTE SENSOR

1. Operating distance may be affected by bright light sources in your home.
2. Do not place an object(s) between the remote control and sensor.
3. Do not use the remote control with another devices remote at the same time.
4. Do not operate the remote control in intense light.

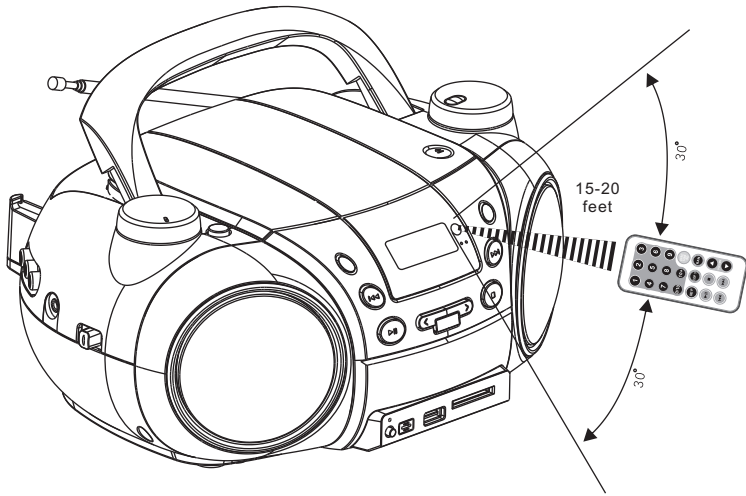

POWER SOURCE

Your player is designed to operate using the included 120V~ 60Hz power adaptor or 8 'C' (UM-2) batteries (Not included). Do not attempt to operate the player from any other power source. You could cause damage to the radio and void your warranty.

A. BATTERY OPERATION

For better performance and longer operating time, we recommend the use of alkaline-type batteries.

1. Remove the Door of Battery Compartment on the Bottom Cabinet.
2. Following the polarity diagram as shown in the battery compartment insert 8 'C' (UM-2) batteries then replace the Door.

IMPORTANT: Be sure that the batteries are installed correctly. Wrong polarity may damage the unit and void the warranty.

BATTERY CARE

1. Use only the size and type of batteries specified.
2. Do not mix old and new batteries.
3. Do not mix alkaline, standard (carbon-zinc) or rechargeable (nickel-cadmium) batteries.
4. If the unit is not to be used for an extended period of time, remove the batteries. Old or leaking batteries can cause damage to the unit and may void the warranty Old or leaking batteries can cause damage to the unit and may void the warranty
5. Do not try to recharge batteries not intended to be recharged; they can overheat and rupture. (Follow battery manufacturer's directions).

6. Do not dispose of batteries in fire, batteries may leak or explode.
7. Remove exhausted batteries from the unit, dispose promptly and properly.

B. AC OPERATION

Insert one end of the AC adaptor (Included) into the DC Jack on the back of the CD-750 and plug the AC adaptor end into a wall outlet with a 120V~ 60Hz power supply. The CD-750 will automatically disconnect the batteries and operate from the AC Power adaptor.

LISTENING TO RADIO

1. Turn ON the CD-750 by pressing the POWER Button. The Power indicator will light.
2. Set the Band Selector on the right hand side of CD-750 to AM or FM.
3. Rotate the Tuning Control to the station you want to listen to. The station frequencies are marked on the dial scale and can be seen through the window on the Tuning Control knob.
4. For FM Stereo reception, set the Function Selector on the left hand side of CD-750 to FM STEREO. The FM STEREO Indicator will light if an FM stereo broadcast is received.
5. To receive a weaker (noisy) FM station, set the Function selector to the "MONO" position. The reception may be improved, but the sound is monaural (MONO).
6. Adjust the volume by turning the VOLUME Control.
7. Switch off the radio by pressing the POWER Button again. The POWER Indicator will turn off.

TIPS FOR BEST RADIO RECEPTION

1. FM Reception - Fully extend and rotate the Telescopic Antenna for the best FM reception.
2. AM Reception - The AM antenna is located inside the CD-750 cabinet. If AM reception is weak, change the position of cabinet until the internal antenna picks up the strongest signal

CD/MP3 OPERATION

This unit not only plays commercial compact discs but also self-complied CD-RW discs.

- Because of non-standardized format definition/production of CD-R/RW, playback quality & performance are not guaranteed.
- The manufacturer is not responsible for the playability of CD-R/RW due to recording conditions such as PC performance, writing software, media properties etc.
- Do not attach a label or seal to either side of the CD-R/RW disc. It may cause a malfunction.

PLAY MODE

Note: The "  " icon indicates that the function is only available when using the Remote Control

1. Turn ON the CD-750 by pressing the POWER Button. The Power indicator will light.
2. Set the Function Selector to the DISC/USB/SD position. The LCD display lights and "rEAd" appears on the Display for a few seconds and "no DISC" will be displayed if no disc is loaded.
3. Press the OPEN/CLOSE to open the CD Lid. Insert a CD with the label facing up and press down on the OPEN/CLOSE again to close the CD Lid until it clicks. The player will start reading the disc and "rEAd" and "DISC" will alternate on the display. Once the player finishes reading the disc, playback starts from the first track.







CD Playback





MP3 Playback

Note:

- a. Since MP3 discs contain more files, it may take more time to read the TOC (table of contents) from the disc.
- b. For MP3 discs, all the files from all folders will form in sequential order.



TO DO	DO THIS
Pause playback	Press  once and again to resume playback.
Stop playback	Press 
Go to next track/MP3 file	Press 
Go back to previous track/MP3 file	Press 

To search back or forward at a high speed	Press and hold  or 
Skip Up or Down the folders on An MP3 disc	Press FOLDER +/- on unit.
Locate a specific track/MP3 file	relevant Numeric Keys "  ".

REPEAT AND RANDOM PLAYBACK

The CD-750 can also playback CD tracks/MP3 files Repeatedly or in Random order.

To Play CD Tracks/MP3 Files Repeatedly (Repeat Play)

1. Press the REPEAT (REP) Button once while playing. The Display will show "REP 1". The single MP3 track/MP3 file will be played repeatedly until the STOP  Button is pressed.
2. Press the REPEAT (REP) Button twice while playing. The Display will show "REP All". All the CD tracks/MP3 files will be played repeatedly until the STOP  Button is pressed.
3. To cancel the REPEAT function, press the "REPEAT" Button repeatedly until "REP 1" or "REP ALL" disappears from the Display.

To Play CD Tracks/MP3 Files In A Random Order

Press "RAN" "" once. A track/file will be selected at Random and playback starts at once..

IMPORTANT:

Because there are so many different MP3 file types available, the CD-750 might not support all of the formats available due to the changing encoding methods.

USB/SD CARD OPERATION

1. Select "DISC/USB/SD" function mode, remove any disc from the Disc Compartment.
Note:
DISC mode will take priority over USB/SD if there is a disc in the Compartment.
2. Insert either a USB Flash Drive into the USB PORT or an SD MEMORY CARD into the SD/MMC CARD Slot located on the front of CD-750.
3. Press the DISC/USB/SD Button repeatedly to toggle between USB and SD Card playback.
4. Follow the same procedure as described in CD/MP3 OPERATION section above for SKIPPING TRACKS FORWARD OR BACKWARD, **REPEAT** or **RANDOM** playback functions.
5. Press the STOP Button and remove the USB or SD Card.

Note:

- i. USB media is hot-swappable, meaning it can be inserted and removed at any given time when not in use. The unit may malfunction if the USB or SD Card is removed suddenly in the middle of playing an audio file, so always make sure the STOP button is pressed before removing the USB or SD Card from the slot.
- ii. If the CD-750 malfunctions or does not operate normally, perform a reset by switching the unit off and on once.

CD RIPPING AND MP3 FILE COPYING

This unit allows you to encode audio tracks from an audio CD and convert them into MP3 format files. You can also copy MP3 files and to save them to a USB Flash Drive or an SD Memory Card.

CD RIPPING

1. In CD Playback mode, insert a USB Flash Drive* or a Flash Memory Card* into the relevant slot,
2. Press "◀◀" or "▶▶" to locate the track you wish to encode then press the "ENCODE" Button on the front panel once. The Copy Indicator, ENCODE, flashes, and "CD" in the LCD Display flashes as well, indicating that encoding is being processed.
3. To stop encoding, press "STOP" ■ once. "STOP" appears in the LCD Display. If "STOP" is not pressed during the encoding process, the successive tracks will be encoded one by one. CD-750 will stop when the last CD track has been encoded. "STOP" will appear on the Display.

Note: If you monitor the audio during the MP3 encoding process, you may hear breaks in the audio playing through the speakers. This is normal and does not affect the audio quality of the final MP3 file that is produced.

We suggest you turn the volume off during the MP3 encoding process and only monitor the audio to check the progress of the song being converted.

COPYING MP3 FILE

MP3 tracks in a CD-Rom disc can also be copied and saved to a USB Flash Drive* or a Flash Memory Card*:

1. In MP3 Playback mode, insert a USB Flash Drive* or a Flash Memory Card* into the relevant slot,
2. Press "◀◀" or "▶▶" to locate the MP3 track you wish to copy and press the **"ENCODE"** Button on the front panel of CD-750 once. The copy indicator lamp on the CD-750 front panel flashes and the display will show **"rEC 001"** and then begin counting up during the copy process, The copy process is completed when the display shows **"rEC 100"**. No sound is heard from the speakers during the copy process.

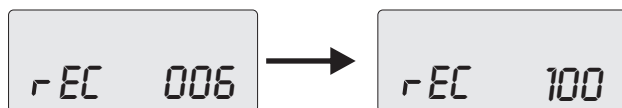

Once the copy process is completed, playback of the track you just copied will begin.

3. To copy another file repeat step 2 of above.

Notes:

- i. USB and flash memory cards are not included and must be purchased separately.
- ii. If a USB Flash Drive and SD Memory Card are both inserted, the USB Flash Drive will always take priority over the SD Memory Card. Remove the USB if you wish to encode or copy to the SD Memory Card.
- iii. When using a large capacity USB Flash Drive or SD Memory Card (e.g. above 2 GB), the initial verification time will be slightly longer.

AUX OPERATION

You can play other music sources (such as an iPod, MP3 or other digital audio player) Through the speakers of this unit by connecting in AUX IN jack to you external player's LINE OUT jack or headphone jack.
jack or headphone jack.

1. Plug one end of the connection cord (not included) into the AUX IN jack on the left hand side of CD-750. Plug the other end of the connection cord into your external player.
2. Power on CD-750 and then the external player.
3. Set the FUNCTION Selector to the LINE IN position.
4. Start playing your external player.
5. Set the volume of the external player to about half of its maximum. Increase the volume of CD-750 until the desired sound level is obtained.

If the output volume of CD-750 is still too low at full volume, gradually increase the volume of the external player to reach the desired sound level.

6. Turn off the attached player and unplug the AUX IN Jack when finish listening.
7. Press the POWER Button once to turn CD-750 off. .

LINE OUT OPERATION

You can connect CD-750 to an external Hi-Fi system by connecting the LINE OUT Socket (15) on the back of CD-750 to the AUX IN Socket of your Hi-Fi system with a RCA cables (Not included).

Remark: The sound from the CD-750 built-in speakers will not be disabled when using the LINE OUT socket. Once you connect CD-750 to an external Hi-Fi system, turn the volume of CD-750 to minimum if you prefer to only hear the sound through your Hi-Fi system.

USING HEADPHONES

Inserting the plug of your headphones into the Headphone jack will enable you to listen in private. When using headphones, the speakers of CD-750 will be disconnected automatically .

READ THIS IMPORTANT INFORMATION BEFORE USING YOUR HEADPHONES

1. Avoid extended play at very high volume as it may impair your hearing.
2. If you experience ringing in your ears, reduce the volume or shut off your unit.
3. Keep the volume at a reasonable level even if your headset is an open-air type designed to allow you to hear outside sounds. Please note that excessively high volume may still block outside sounds.

CARE AND MAINTENANCE

1. Before cleaning unplug the unit. Clean your unit with a damp (never wet) cloth. Solvent or detergent should never be used.
2. Avoid leaving your unit in direct sunlight or in hot, humid or dusty places.
3. Keep your unit away from heating appliances and sources of electrical noise such as fluorescent lamps or motors.
4. If drop-outs or interruptions occur in the music during CD play, or if the CD fails to play at all, its bottom surface may require cleaning. Before playing, wipe the disc from the center outwards with a good soft cleaning cloth.

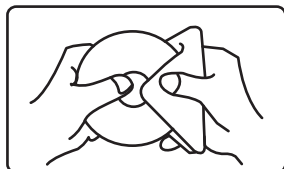

TROUBLESHOOTING GUIDE

If you experience difficulties in the use of this system please check the following before calling 1-800-777-5331 for Customer Service and Support.

Symptom	Possible Cause	Solution
Noise or sound distorted on AM or FM broadcast	Station not tuned properly for AM or FM. FM: Telescopic antenna is not fully extended. AM: The bar antenna is not positioned correctly	Retune the AM or FM broadcast station. FM: Fully extend and rotate the telescopic antenna AM: Reposition the unit until the best reception is obtained.
AM or FM no sound	Unit not in AM or FM mode. Volume set at minimum	Slide Function Switch to AM or FM position Increase Volume
CD player will not play	Unit not in CD function mode. CD is installed incorrectly. If the CD is self-compiled, the media used may not be compatible with the player.	Select CD function mode. Insert CD with label side up. Use better quality blank media and retest.
USB will not play	Unit not in CD function mode USB function is not selected	Select CD function mode. Press SOURCE to change from CD to USB mode.
SD Card will not play	Unit not in CD function mode SD function is not	Select CD function mode. Press DISC/USB/SD to change from CD to SD mode.
CD skips while playing	Disc is dirty or scratched	Wipe CD with clean cloth or use another disc.
Intermittent sound from CD Player	Dirty or defective disc Dirty pick up lens Player is subject to excessive shock or vibration	Clean or replace the defective disc Use a CD-lens cleaning disc to clean the lens Relocate the player away from shock or vibration
No sound when played in the AUX Mode	Power to external source (CD, MP3 etc) not switched on Connection to external source (CD, MP3 etc) is incorrect: e.g. Audio cable may have been inserted to AUX IN of external source. Volume Control is at minimum.	Switch on the power of the external source. Reconnect the audio cable to the LINE OUT of the external source. Adjust both the volume controls of CD-477 and that of the external source.
The Remote Control does not work	Battery is inserted incorrectly Check the battery if it is worn	Insert Battery correctly Replace the battery if it is worn

90 DAY LIMITED WARRANTY AND SERVICE VALID IN THE U.S.A ONLY

SPECTRA MERCHANDISING INTERNATIONAL, INC. warrants this unit to be free from defective materials or factory workmanship for a period of 90 days from the date of original customer purchase and provided the product is utilized within the U.S.A. This warranty is not assignable or transferable. Our obligation under this warranty is the repair or replacement of the defective unit or any part thereof, except batteries, when it is returned to the SPECTRA Service Department, accompanied by proof of the date of original consumer purchase, such as a duplicate copy of a sales receipt.

You must pay all shipping charges required to ship the product to SPECTRA for warranty service. If the product is repaired or replaced under warranty, the return charges will be at SPECTRA's expense. There are no other express warranties other than those stated herein.

This warranty is valid only in accordance with the conditions set forth below:

1. The warranty applies to the SPECTRA product only while:
 - a. It remains in the possession of the original purchaser and proof of purchase is demonstrated.
 - b. It has not been subjected to accident, misuse, abuse, improper service, usage outside the descriptions and warnings covered within the user manual or non-SPECTRA approved modifications.
 - c. Claims are made within the warranty period.
2. This warranty does not cover damage or equipment failure caused by electrical wiring not in compliance with electrical codes or SPECTRA user manual specifications, or failure to provide reasonable care and necessary maintenance as outlined in the user manual.
3. Warranty of all SPECTRA products applies to residential use only and is void when products are used in a nonresidential environment or installed outside the United States.

This warranty gives you specific legal rights, and you may also have other rights which vary from state to state. TO OBTAIN SERVICE please remove all batteries (if any) and pack the unit carefully and send it freight prepaid to SPECTRA at the address shown below. IF THE UNIT IS RETURNED WITHIN THE WARRANTY PERIOD shown above, please include a proof of purchase (dated cash register receipt) so that we may establish your eligibility for warranty service and repair of the unit without cost. Also include a note with a description explaining how the unit is defective. A customer service representative may need to contact you regarding the status of your repair, so please include your name, address, phone number and email address to expedite the process.

IF THE UNIT IS OUTSIDE THE WARRANTY PERIOD, please include a check for \$40.00 to cover the cost of repair, handling and return postage. All out of warranty returns must be sent prepaid.

It is recommended that you contact SPECTRA first at 1-800-777-5331 or by email at service@spectraintl.com for updated information on the unit requiring service. In some cases the model you have may be discontinued, and SPECTRA reserves the right to offer alternative options for repair or replacement.

SPECTRA MERCHANDISING INTERNATIONAL, INC.

4230 North Normandy Avenue,

Chicago, IL60634, USA.

1-800-777-5331

To register your product, visit the link on the website below to enter your information.

<http://www.spectraintl.com/wform.htm>

[0312]

Printed in China